

# BMSKTOPASM369BT(kc)

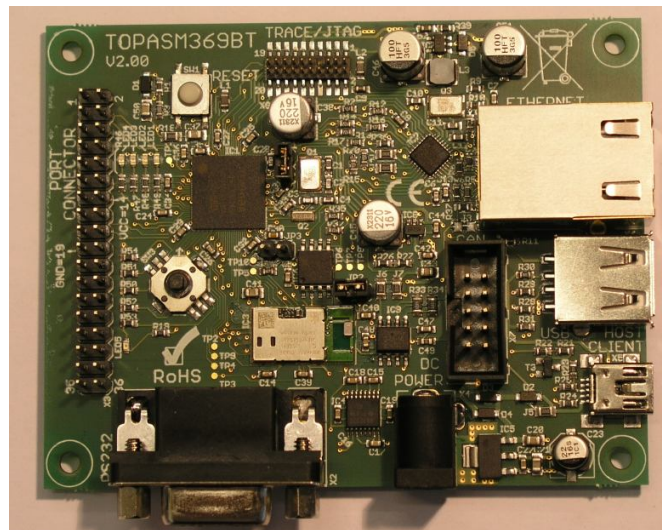

## Hardware Guide

Board Version 2.00  
Manual Version: HGM369BTV2\_02

Date: 27.01.2014

By: Toshiba Electronics Europe GmbH  
European LSI Design Eng. Center – ELDEC

Microcontroller information:

<http://www.toshiba-components.com/microcontroller/index.html>

Wireless LSI information:

<http://www.toshiba-components.com/wireless/index.html>

## 1. Introduction

The “BMSKTOPASM369BT(kc) version 2” starter kit makes it possible to easily evaluate TOSHIBA Bluetooth® LSI “CHIRON”, TC35661 and the Microcontroller TMPM369FDG that offer the connectivity as Ethernet, CAN, USB host, USB device, UART, SIO, SPI and I2C.

The board uses the Panasonic (PIDEU) Bluetooth® module PAN1026 that has embedded the TC35661.

<http://pideu.panasonic.de/products/wireless-modules/bluetooth/bluetooth-40-dual-mode/pan1026-bluetooth-classic-and-low-energy-embedded-dual-mode-module.html>

### Starter-Kit Content:

- Toshiba TOPAS369BT Board
- Segger J-Link JTAG/SWD Emulator with USB interface including J-Link 19-pin Cortex-M Adapter and USB Cable

### Embedded SPP Application Note:

<http://www.toshiba-components.com/bluetooth/index.html>

## 1. Hardware Setup of the M369BT STK MCU Board

Place the MCU Board in front of you as below. The major connectors on the board are as follows.

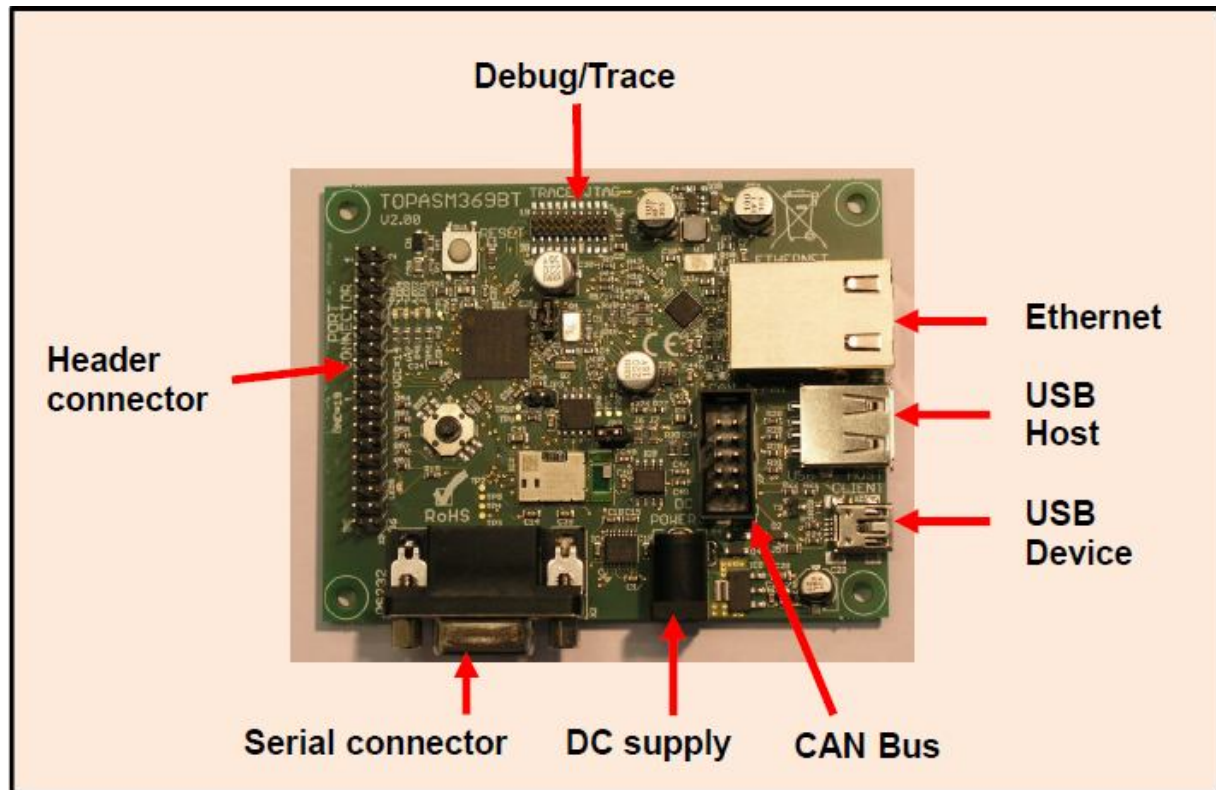

The board can be powered in three ways:

- By the USB client connector
- By the debug connector
- By the DC jack connector

These three inputs are wired OR by diodes. There is no need to select a power input by a jumper.

!!! Please note when you make use of the power supply by a debug probe like the JLINK that comes with that starter kit, that this function is disabled by default. This can be enabled by the **J-Link Commander** (JLink.exe) is a command line based utility that is part of the Segger J-Link software package. When you enter at the prompt the command "power on perm" power supply to the target will be done by the J-LINK.

<http://www.segger.com/j-link-commander.html>

The main voltage of 3.3 volt is derived by a linear regulator. Hence DC jack input voltage must be in a range from 5...12 volts.

The USB host supply voltage of 5 volts is generated by a step-up converter from the 3.3 V bus. Please note that the current capability of this USB host is much lower than the USB specification of 500mA (~100mA).

The +5V power of the USB host connector is switchable via port PK3 (active high enable) and has overcurrent detection connected to PK1 (active low trigger).

There are a few buttons and LEDs

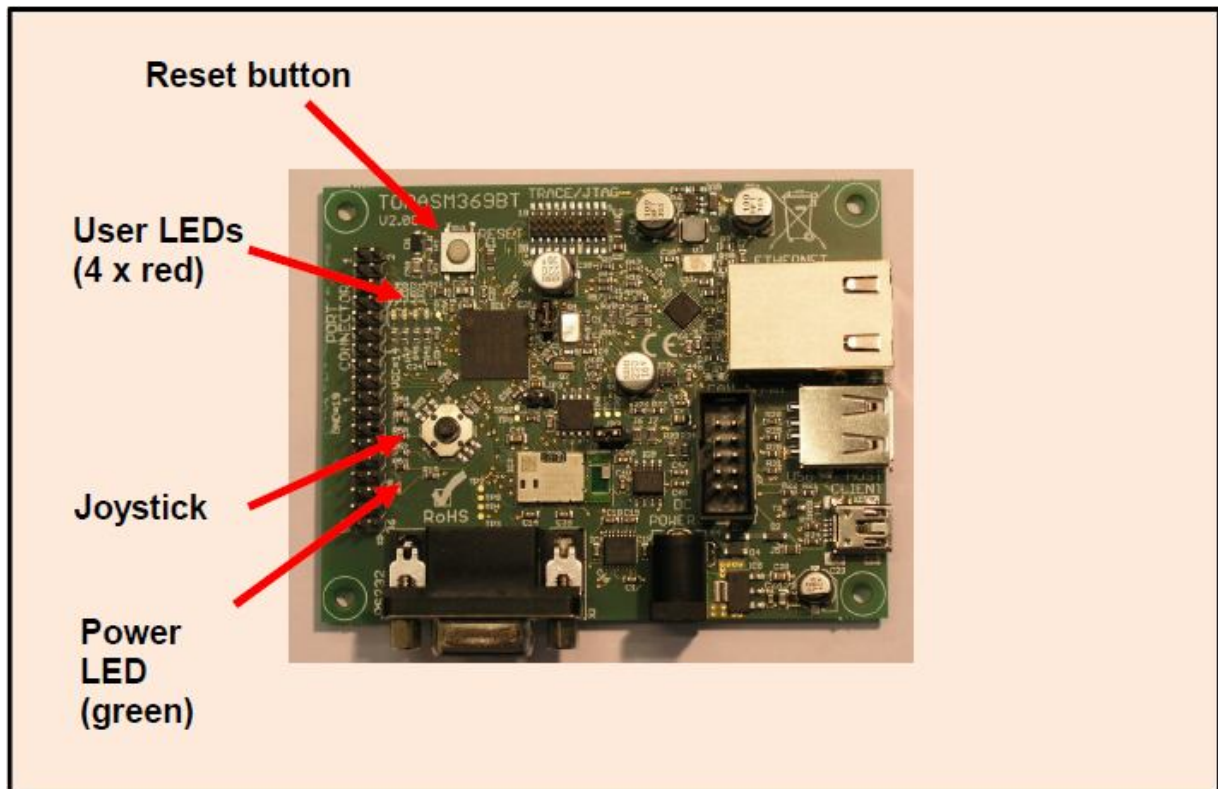

- The joystick is connected to the port PD0...PD4.
- The user LEDs are connected to the port PC0...PC3.

There are some jumpers for power measurement and a jumper to enter the device operation mode named boot mode.

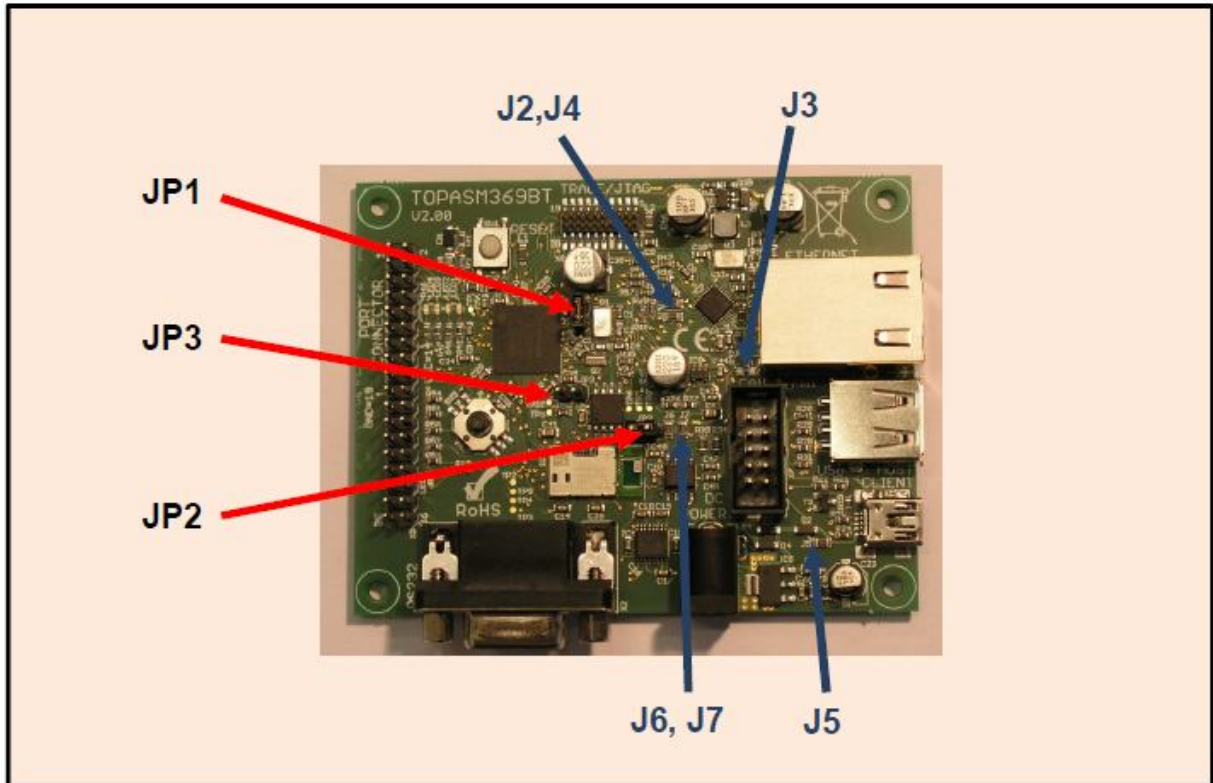

#### Jumpers JPx:

The jumpers JP1 and JP2 are normally closed. They can be opened to separate the microcontroller or the Bluetooth module from VCC and to insert an ammeter there in order to measure current draw.

- JP1 is for TMPM369.
- JP2 is for PAN1026.
- JP3 can be used to connect the BOOT-mode-pin of the microcontroller to GND.

#### Resistors Jx:

These 0-Ohm resistors can be easily identified because their SMD size is 0805 (regular resistors are SMD size 0603).

They are populated by default, except J3, and can be de-soldered to change the behavior of the board.

- J2 connects of PHY interrupt to MCU port PI3
- J3 connects LED of the PHY to MCU port PH7

- J4 connects reset input of the PHY to the reset button.
- J5 connects power input of the usb client connector to MCU port PK0
- J6 connects STB line of ZJA1040 CAN-Transceiver to GND.
- J7 connects pin 5 of CAN-connector to GND.

## 2. Pin Out of Connectors

### CAN Connector

	1	2	GND
CAN_L	3	4	CAN_H
GND	5	6	
	7	8	V+ ( 5V )
	9	10	

*Connector : CAN Signals according to CiA*

**Pin Header Connector**

TMPM369 has several ports. These ports are also used as input/output pins as well as for built-in peripheral functions. For the header pin some terminal has been selected. The description below shows the major function, for all please see TMPM369 Data Sheet.

PJ0 / AINB4	1	2	PJ1 / AINB5
PJ2 / AINB6	3	4	PJ3 / AINB7
PAN - GPIO05/FSYNC	5	6	GPIO16/DIN - PAN
PAN - GPIO17/CS0X	7	8	GPIO18/CS1X - PAN
DA0	9	10	DA1
PIO / AIN0 / INT9	11	12	PI1 / AIN1 / INTA
PI2 / AIN2 / INTB	13	14	VCC
PE4 / SCLK1 / CTS1 / TB2OUT	15	16	PE5 / TXD1
PE6/ RXD1	17	18	PE7 / INT6 / TB2IN
GND	19	20	PF6 / DSR4 / SI1 / SCL1
PF7 / DTR4 / SO1/SDA1	21	22	PG0 / MT0IN
PG1	23	24	PG2 / MTOUT10 /MTTB0IN
PG3 / MTOUT00 / MTTB0OUT	25	26	PG4 / SP1CLK
PG5 / SP1DO	27	28	PG6
PG7 / SP1FSS	29	30	PB2 /SP2CLK / MTOUT03 /MTTB3OUT
PB3 / SP2DO /MTOUT13 /MTTB3IN	31	32	PB4 / SP2DI / INT7
PB5 / SP2FSS / MT3IN / INT1	33	34	PH1 / TB4OUT / SI2 / SCL2
PH0 / TB5OUT / MT2IN / SO2/SDA2	35	36	/NMI

*Connector: Pin Header*

*Note: BMSKTOPASM369BT(kc) version 1 has different pin header.*

### 3. Schematics

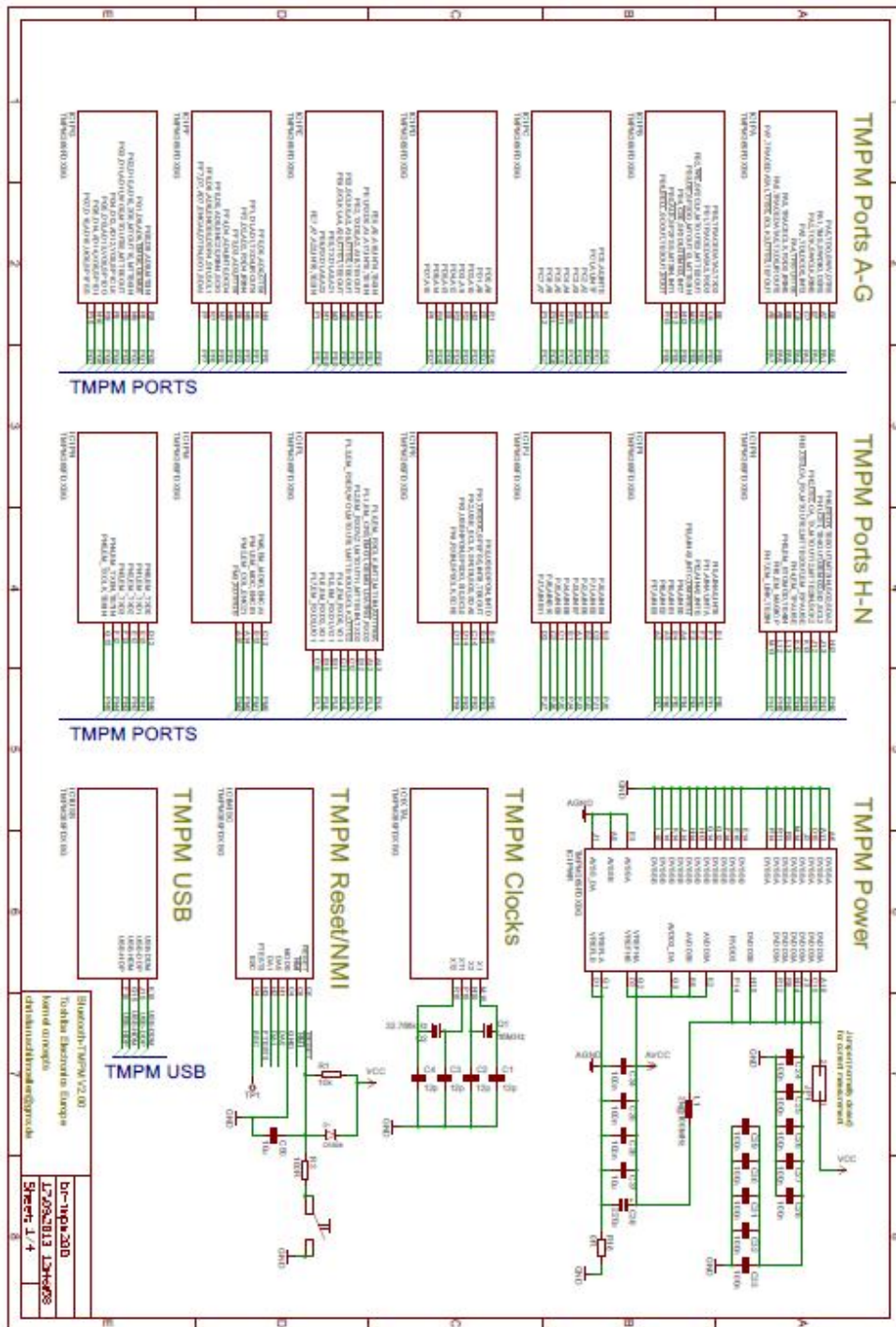



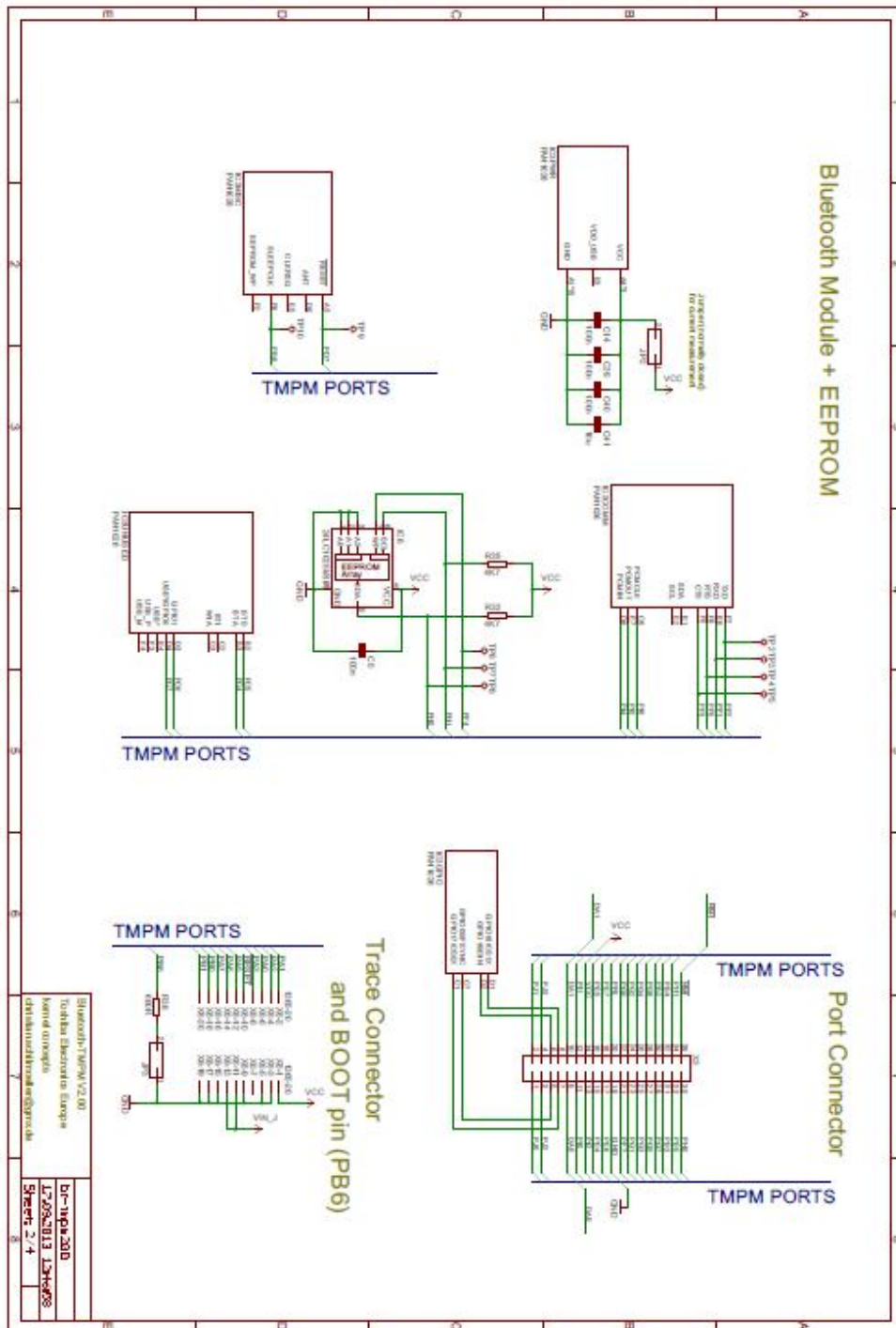

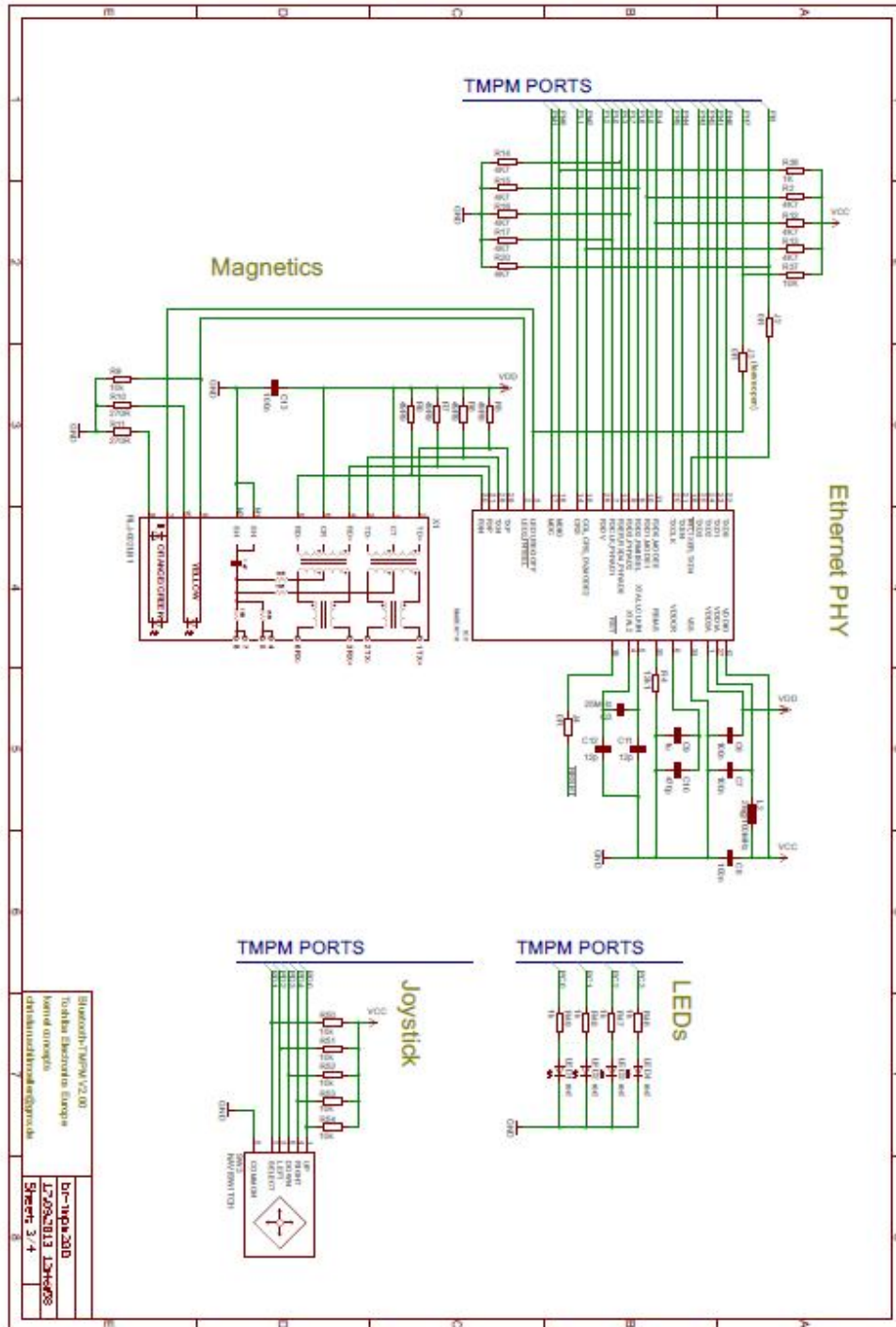

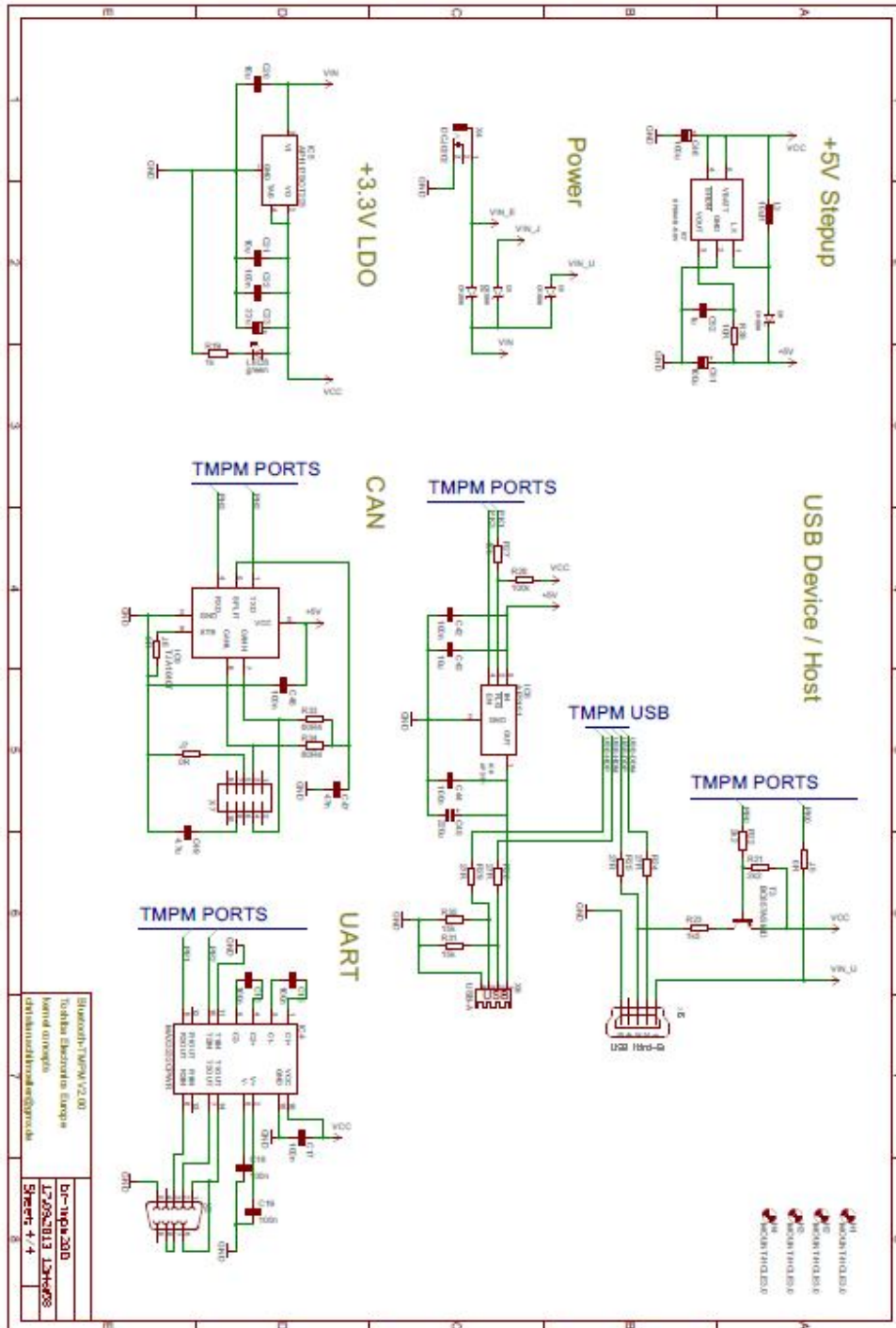

Shikantech-TMPM V2.00  
 Toshiba Electronics Europe  
 Kundengruppe  
 cdf@shikantech.com  
 Sheet 4-4

bi-1100a-20D  
 L2-09-0113\_13H-028  
 Sheet 4-4

## 4. Important Notice

- **Intended Usage**
  - The board should be used for evaluation. It should be used in proper environment. It is not intended and not recommended to be used in any final product.
- **Conformity**
  - The board passed the requirements of the radiated emission according to EN 61326-1 (CISPR 11) class A.
  - When using the boards in a Class B environment (residential and small commercial area) there is possibility to have increased radiation due to the LAN LSI oscillator frequency.
- **Known Limitations**
  - EEPROM: Please note that the schematics has been made using an EEPROM that use A2 terminal as "User Configurable Chip Select" and therefore it has been connected to logical 0 (GND). The 24LC1025 on the board use that terminal as block and not as chip select and it has to be connected to logical 1 (VCC). As a result only lower block, 512K bit, can be used for evaluation.

## 5. Revisions

Revision	Date	Description
01	30.07.2013	Initial Version
02	27.01.2014	Add chapter "1. Important Notice" and "Revisions". Update pictures, schematics and some contents revised.

## 6. Disclaimer

### RESTRICTIONS ON PRODUCT USE

- Toshiba Corporation, and its subsidiaries and affiliates (collectively "TOSHIBA"), reserve the right to make changes to the information in this document, and related hardware, software and systems (collectively "Product") without notice.
- This document and any information herein may not be reproduced without prior written permission from TOSHIBA. Even with TOSHIBA's written permission, reproduction is permissible only if reproduction is without alteration/omission.
- Though TOSHIBA works continually to improve Product's quality and reliability, Product can malfunction or fail. Customers are responsible for complying with safety standards and for providing adequate designs and safeguards for their hardware, software and systems which minimize risk and avoid situations in which a malfunction or failure of Product could cause loss of human life, bodily injury or damage to property, including data loss or corruption. Before customers use the Product, create designs including the Product, or incorporate the Product into their own applications, customers must also refer to and comply with (a) the latest versions of all relevant TOSHIBA information, including without limitation, this document, the specifications, the data sheets and application notes for Product and the precautions and conditions set forth in the "TOSHIBA Semiconductor Reliability Handbook" and (b) the instructions for the application with which the Product will be used with or for. Customers are solely responsible for all aspects of their own product design or applications, including but not limited to (a) determining the appropriateness of the use of this Product in such design or applications; (b) evaluating and determining the applicability of any information contained in this document, or in charts, diagrams, programs, algorithms, sample application circuits, or any other referenced documents; and (c) validating all operating parameters for such designs and applications. **TOSHIBA ASSUMES NO LIABILITY FOR CUSTOMERS' PRODUCT DESIGN OR APPLICATIONS.**
- Product is intended for use in general electronics applications (e.g., computers, personal equipment, office equipment, measuring equipment, industrial robots and home electronics appliances) or for specific applications as expressly stated in this document. Product is neither intended nor warranted for use in equipment or systems that require extraordinarily high levels of quality and/or reliability and/or a malfunction or failure of which may cause loss of human life, bodily injury, serious property damage or serious public impact ("Unintended Use"). Unintended Use includes, without limitation, equipment used in nuclear facilities, equipment used in the aerospace industry, medical equipment, equipment used for automobiles, trains, ships and other transportation, traffic signaling equipment, equipment used to control combustions or explosions, safety devices, elevators and escalators, devices related to electric power, and equipment used in finance-related fields. Do not use Product for Unintended Use unless specifically permitted in this document.
- Do not disassemble, analyze reverse-engineer, alter, modify, translate or copy Product, whether in whole or in part.
- Product shall not be used for or incorporated into any products or systems whose manufacture, use, or sale is prohibited under any applicable laws or regulations.
- The information contained herein is presented only as guidance for Product use. No responsibility is assumed by TOSHIBA for any infringement of patents or any other intellectual property rights of third parties that may result from the use of Product. No license to any intellectual property right is granted by this document, whether express or implied, by estoppel or otherwise.
- **ABSENT A WRITTEN SIGNED AGREEMENT, EXCEPT AS PROVIDED IN THE RELEVANT TERMS AND CONDITIONS OF SALE FOR PRODUCT, AND TO THE MAXIMUM EXTENT ALLOWABLE BY LAW, TOSHIBA (1) ASSUMES NO LIABILITY WHATSOEVER, INCLUDING WITHOUT LIMITATION, INDIRECT, CONSEQUENTIAL, SPECIAL, OR INCIDENTAL DAMAGES OR LOSS, INCLUDING WITHOUT LIMITATION, LOSS OF PROFITS, LOSS OF OPPORTUNITIES, BUSINESS INTERRUPTION AND LOSS**

**OF DATA, AND (2) DISCLAIMS ANY AND ALL EXPRESS OR IMPLIED WARRANTIES AND CONDITIONS RELATED TO SALE, USE OF PRODUCT, OR INFORMATION, INCLUDING WARRANTIES OR CONDITIONS OF MERCHANTABILITY, FITNESS FOR A PARTICULAR PURPOSE, ACCURACY OF INFORMATION, OR NONINFRINGEMENT.**

- Do not use or otherwise make available Product or related software or technology for any military purposes, including without limitation, for the design, development, use, stockpiling or manufacturing of nuclear, chemical, or biological weapons or missile technology products (mass destruction weapons). Product and related software and technology may be controlled under the Japanese Foreign Exchange and Foreign Trade Law and the U.S. Export Administration Regulations. Export and re-export of Product or related software or technology are strictly prohibited except in compliance with all applicable export laws and regulations.
- Product may include products subject to foreign exchange and foreign trade control laws.
- The technical information described in this document is subject to foreign exchange and foreign trade control laws.
- Please contact your TOSHIBA sales representative for details as to environmental matters such as the RoHS compatibility of Product. Please use Product in compliance with all applicable laws and regulations that regulate the inclusion or use of controlled substances, including without limitation, the EU RoHS Directive. TOSHIBA assumes no liability for damages or losses occurring as a result of noncompliance with applicable laws and regulations.